



Engelking Elektronik GmbH
Albstrasse 16
D-78609 Tuningen
Germany
Tel: 07464/9865-0
Fax: 07464/9865-71
eMail: info@engelking.de
http://www.engelking.de

NEWS @ ENGELKING

Responsible editor: Thimo Hamma
Release date : immediate

Hubbell Industrial Ethernet and Harsh Environment Connectors

This Industrial Ethernet System provides leading edge Category 5e and 6 network transmission performance suitable for industrial and other harsh environments. This system incorporates the use of data connectivity jacks which feature the keystone latching mechanism, in a rugged sealed housing providing IP67 rated protection.

The system allows extension of a LAN to include automation equipment and manufacturing or process control equipment.

The product is intended to provide added protection in harsh environments such as convention centers, food processing plants, outdoor billboards and display screens, medical and other environments which require added protection from moisture, corrosion, dust-debris, vibration and chemicals.

Industrial Ethernet
and Harsh Environment Connectors

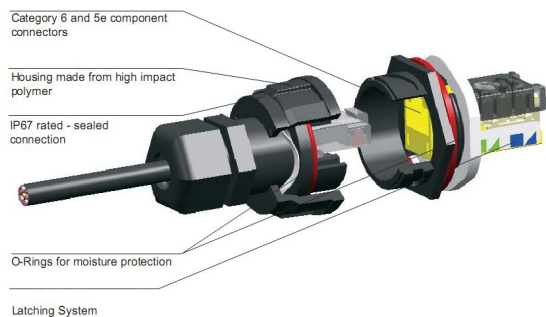

Engelking Elektronik GmbH
Albstr. 16
D-78609 Tuningen
www.engelking.de
Tel: 07464-9865-0
Fax: 07464-9865-71
Beratung & Verkauf:
Thimo Hamma
Tel: 07464-9865-21