

MAGNUM

Maß der Dinge. Seit mehr als einem Jahrzehnt.

The Measure of Things. For over a decade.





Seit dem Jahr 2004 stehen drei Generationen TECHART Magnum
für unübertroffene Individualisierung auf Basis der Porsche Cayenne Modelle.
Für unverwechselbares Design, atemberaubende Performance und höchste Qualität.

Willkommen zum neuen Maß der Dinge.

Der neue TECHART Magnum. Premium-Individualisierung für die vierte Cayenne Generation.

Since 2004, three TECHART Magnum Generations have been synonymous
with unsurpassed Premium Refinement based on the Porsche Cayenne models.
Renowned for unmistakable design, breathtaking performance and superior quality

Welcome to the New Measure of Things.

The all new TECHART Magnum. Premium Refinement for the 4th Cayenne Generation.



TECHART



magnum





Lackierung

Paint

<p>Individuellackierung in Sonderfarbe, glänzend</p>	<p>Individual Paint to Sample custom color, glossy</p>	058.108.010.998	<input type="checkbox"/>	<input type="checkbox"/>	<input type="checkbox"/>	<input type="checkbox"/>	<input type="checkbox"/>	<input type="checkbox"/>
<p>Individuellackierung in Sonderfarbe, matt</p>	<p>Individual Paint to Sample custom color, matt</p>	058.108.011.998	<input type="checkbox"/>	<input type="checkbox"/>	<input type="checkbox"/>	<input type="checkbox"/>	<input type="checkbox"/>	<input type="checkbox"/>
<p>Individuellackierung in Effektfarbe, matt oder glänzend</p>	<p>Individual Paint to Sample special effect paint, matt or glossy</p>	058.108.012.998	<input type="checkbox"/>	<input type="checkbox"/>	<input type="checkbox"/>	<input type="checkbox"/>	<input type="checkbox"/>	<input type="checkbox"/>

Cayenne
Cayenne Diesel / S Diesel
Cayenne S
Cayenne S E-Hybrid
Cayenne GTS
Cayenne Turbo / Turbo S

Das TECHART Magnum Aerokit ist auch für alle Porsche Cayenne Modelle mit Anhängenzugvorrichtung ab Werk sowie für US-Fahrzeugausführungen erhältlich. Zusätzlich haben Sie die Möglichkeit, Bestandteile des TECHART Magnum Aerokits nach Ihren Wünschen zu variieren. Zum Beispiel sind Grills, Airblades und weitere Bestandteile in Wunschfarbe lackiert oder Schwarz matt erhältlich. Das Tagfahrlichtsystem wird wahlweise in elegantem Chrom oder sportlichem Schwarz ausgeführt. Die Nebelscheinwerfer stehen in Halogen- oder LED-Technologie zur Verfügung. All diese Wahlmöglichkeiten sorgen dafür, dass Ihr TECHART Magnum so aussieht, wie Sie es sich wünschen. Mit sportlichen Kontrasten oder elegant Ton in Ton. Ihr TECHART Kundenberater informiert Sie gerne über alle TECHART Magnum Varianten und berät Sie individuell.

The TECHART Magnum Aerokit is also available for all Porsche Cayenne models with towbar system as well as for all US-versions. For maximum individualization opportunities, parts of the TECHART Magnum Aerokit can be varied and combined according to your preferences. Such as the grills, airblades and other styling parts which can be ordered in custom color or in matt black finish. The Daytime Running Light System is available in Chrome or Black in order to provide a seamless elegant or sport-focused look. The fog lights are available in Halogen or LED technology to fit the light color or the base vehicle's headlights. These are just a few examples of the diversity of the new TECHART Magnum Program, providing all options to make your Cayenne model individually yours. Your sales manager at TECHART will be happy to give any assistance.



D BB X 4800

TECHART www.techart.de TECHART



Im Detail: Die TECHART Magnum Frontverkleidung

- 1: TECHART Magnum Bugteil in eigenständigem Design
- 2: Montagevorbereitung für PAS Radarsensor
- 3: Abschlussblende Schlossträger
- 4: Luftführung Wasserkühler
- 5: Montagevorbereitung für Scheinwerferreinigungsanlage
- 6: TECHART Tagfahrlichtsystem
- 7: Airblades mit Lufteinlass und Aufnahme für TECHART Tagfahrlichtsystem
- 8: Frontgrill
- 9: Frontsplitter, 3-teilig
- 10: Unterbodenverkleidung mit Service-Öffnungen links und rechts
- 11: Lufteinlässe zur Bremsanlage
- 12: Nebelscheinwerferereinheit mit Aufnahme für Lufteinlass
- 13: Kühlluftführung zur Bremsanlage
- 14: Luftführung Ladeluftkühler
- 15: Montagevorbereitung für Positionsleuchten (USModelle)
- 16: Montagevorbereitung für Sensoren ParkAssistent
- 17: Radhausträger zur Montage an original Befestigungspunkten

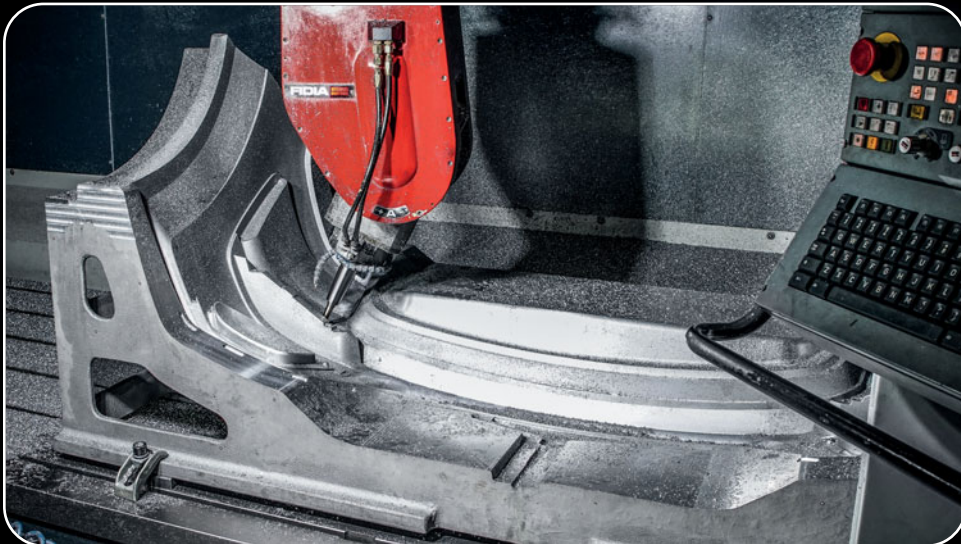

In Detail: The TECHART Magnum Front Apron

- 1: TECHART Magnum Front Apron, distinctive, powerful design
- 2: Mounting device for PAS radar sensor
- 3: Mounting cover trim
- 4: Water cooler air duct
- 5: Mounting device for headlight cleaning system
- 6: TECHART Daytime Running Light
- 7: Airblades with air intake and gear for TECHART Daytime Running Light
- 8: Central air intake grill
- 9: Front Splitter, 3-parts
- 10: Underfloor structure with integrated service lids left/right
- 11: Lower air intakes (brake system)
- 12: Auxiliary fog light unit with gear for lower air intake
- 13: Braking system air duct
- 14: Intercooler air duct
- 15: Mounting device for position lamps (US-vehicles)
- 16: Mounting device for ParkAssist sensors
- 17: Wheel arch mount, uses original mounting points

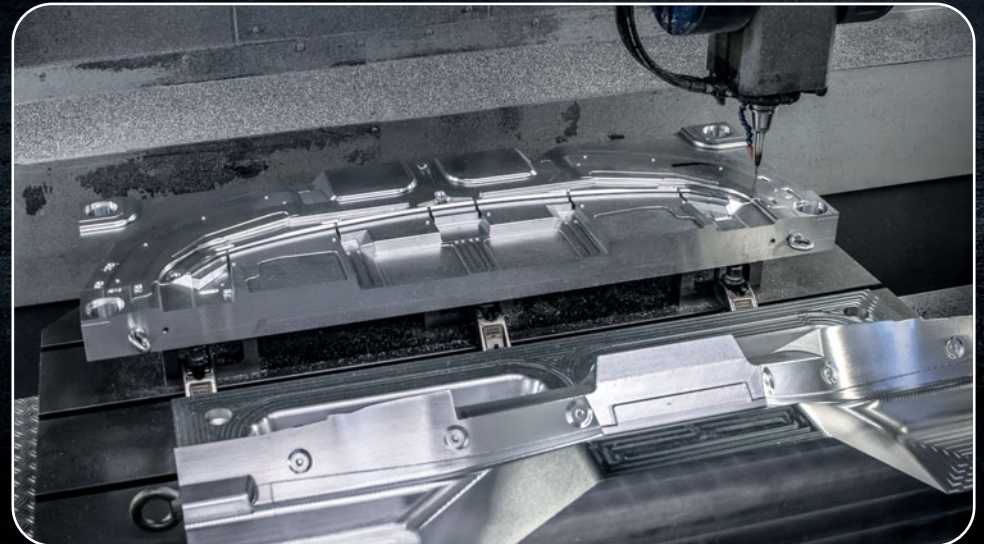

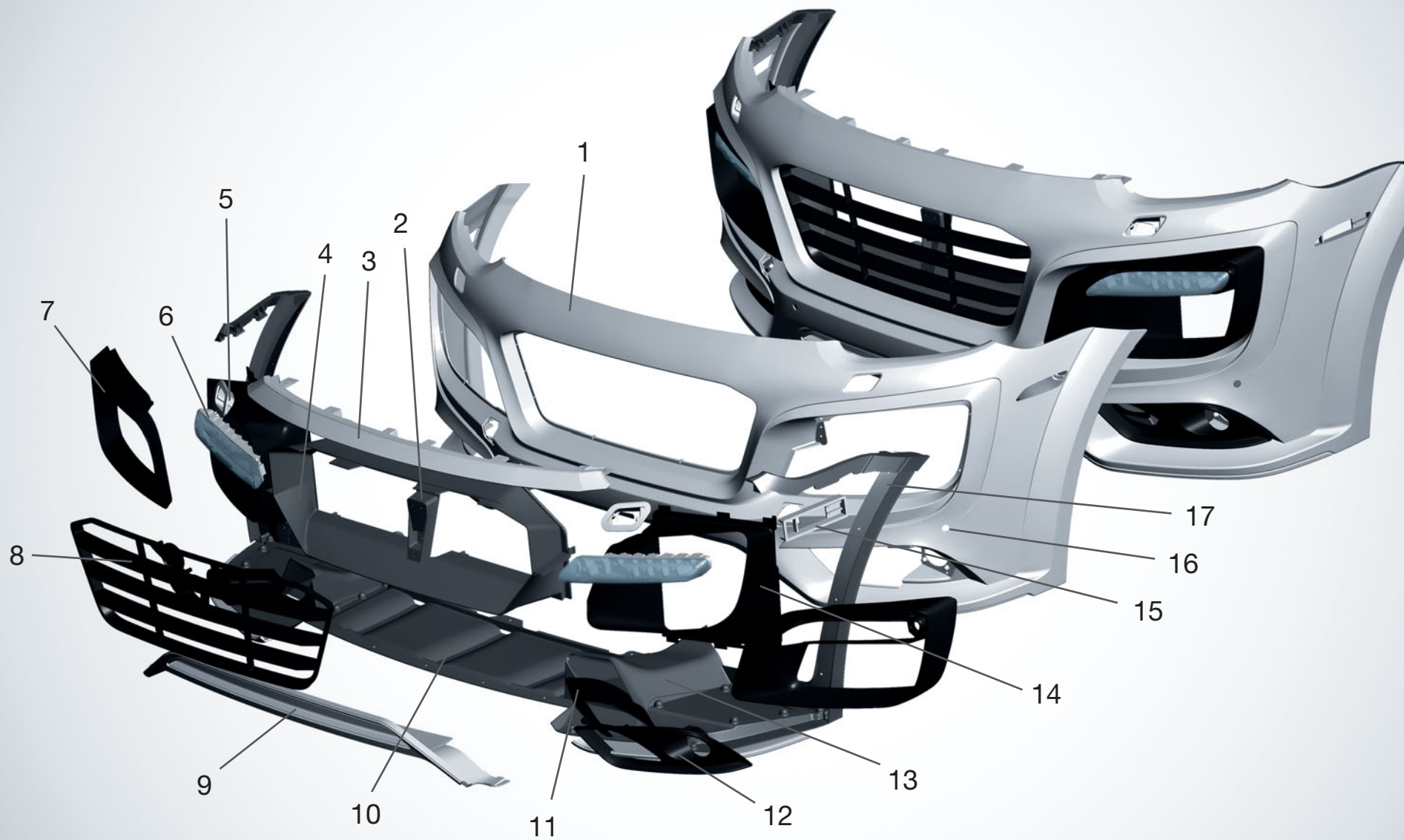



MAGNUM

D BB X 4800
TECHART www.techart.de TECHART



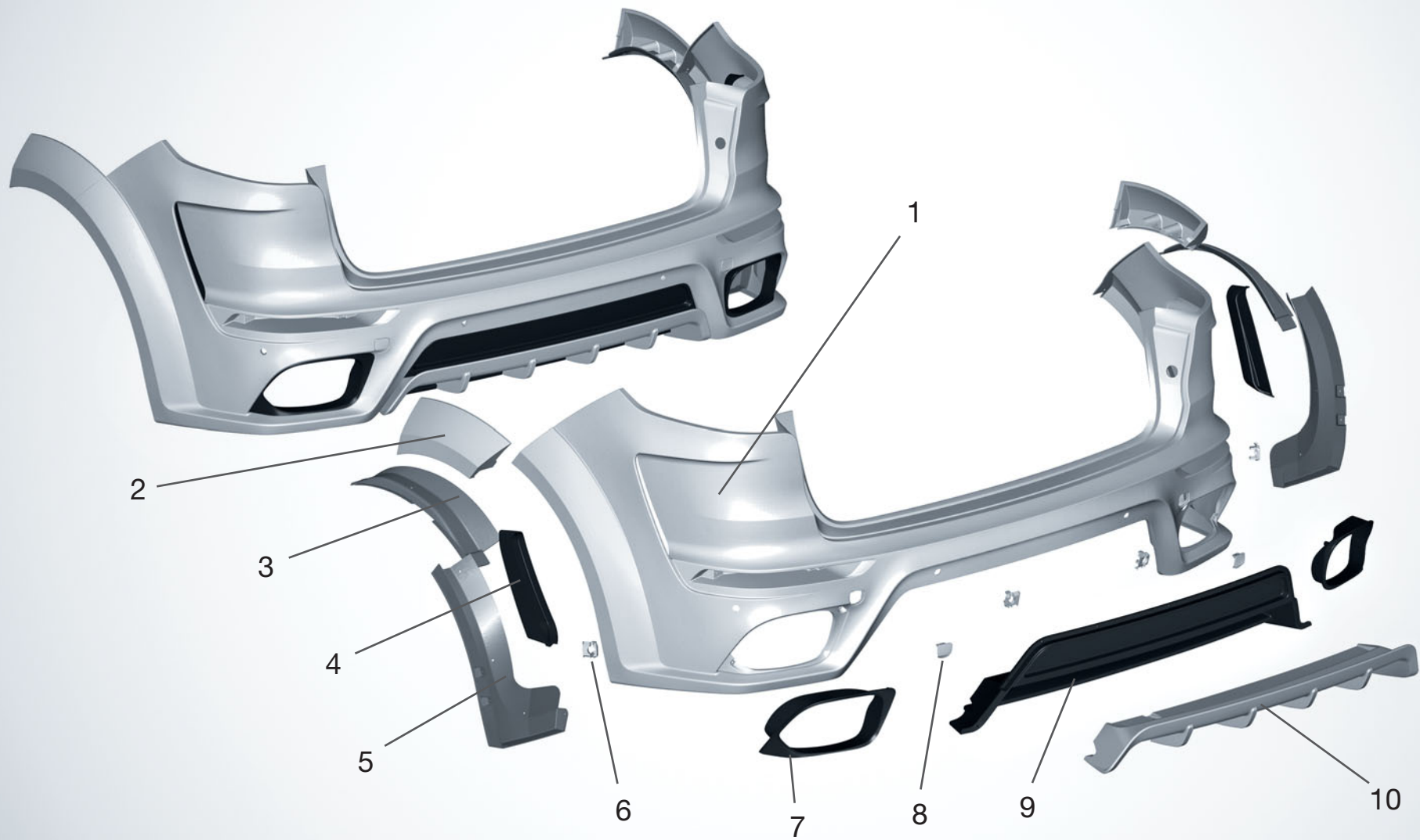

Im Detail: TECHART Magnum Heck- und Seitenverkleidungen

- | | |
|--|---|
| 1: TECHART Magnum Heckschürze, in eigenständigem Design | 10: Heckdiffusor. Abnehmbar für Fahrzeuge mit Anhängезugvorrichtung sowie mit elektronischer Sperre gegen Auslösen des elektrisch betätigten Kugelkopfs bei eingesetztem Diffusor |
| 2: Radhausverbreiterung Heckschürze | 11: Radhausverbreiterung mit Türflächenverkleidung hinten |
| 3: Träger Radhausverbreiterung | 12: Träger Radhausverbreiterung |
| 4: Zierelement Luftauslassoptik | 13: Zierleiste Fondtür |
| 5: Radhausträger zur Montage an original Befestigungspunkten | 14: Seitenschwellerverkleidung |
| 6: Montagevorbereitung für Sensoren ParkAssistent | 15: Türflächenverkleidung vorn |
| 7: Endrohrblende | 16: Zierleiste Vordertür |
| 8: Klappe für Abschlepphaken | 17: Radhausverbreiterung vorn |
| 9: Heckdiffusor-Rahmen | |

In Detail: TECHART Magnum Bodykit - Rear and Side

- | | |
|--|--|
| 1: TECHART Magnum Rear Apron, distinctive, powerful design | 10: Rear Diffusor. Detachable for vehicles with towbar system and equipped with safety locking system (prevents release of electrically deployed towball while diffusor is attached) |
| 2: Rear wheel arch extension | 11: Combined rear wheel arch extension and rear door panel |
| 3: Wheel arch extension mount | 12: Wheel arch extension mount |
| 4: Design trim air outlet element | 13: Rear door trim |
| 5: Wheel arch mount, uses original mounting points | 14: Side skirt panel |
| 6: Mounting device for ParkAssist sensors | 15: Front door panel |
| 7: Tailpipe design trim | 16: Front door trim |
| 8: Tow-hook lid | 17: Front wheel arch extension |
| 9: Rear diffusor surround | |

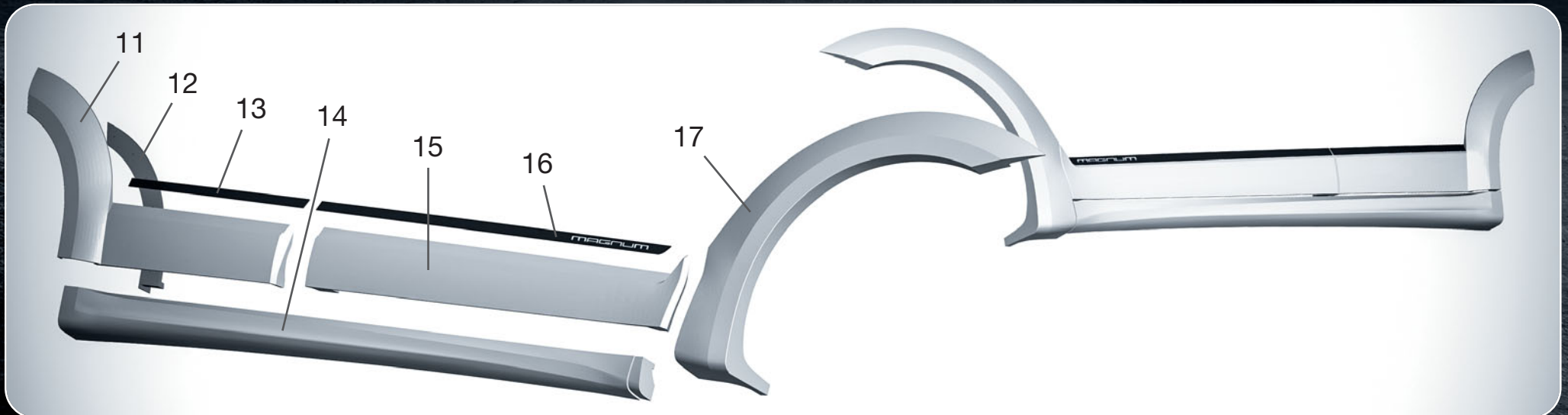





Motorleistung

Performance

<p>TECHART Motorleistungssteigerung TA 058/SD1 + 26 kW (+ 35 PS), + 100 Nm</p> <p>Gesamtleistung: 309 kW (420 PS), 950 Nm</p> <p>Fahrleistungen: 0-100 km/h: 5,2 s, v_{max}: 256 km/h</p>	<p>TECHART Engine Powerkit TA 058/SD1 + 26 kW (+ 35 PS), + 100 Nm (+ 74 lb.-ft.)</p> <p>Total Power Output: 309 kW (420 hp), 950 Nm (701 lb.-ft.)</p> <p>Driving Performance: 0-100 km/h: 5.2 s, v_{max}: 256 km/h</p>	058.300.431.009	<input checked="" type="checkbox"/> <input type="checkbox"/> <input type="checkbox"/> <input type="checkbox"/> <input type="checkbox"/> <input type="checkbox"/>
<p>TECHART Motorleistungssteigerung TA 058/T1 + 59 kW (+ 80 PS), + 90 Nm</p> <p>Gesamtleistung: 441 kW (600 PS), 840 Nm</p> <p>Fahrleistungen: 0-100 km/h: 3,9 s, v_{max}: 290 km/h</p>	<p>TECHART Engine Powerkit TA 058/T1 + 59 kW (+ 80 PS), + 90 Nm (+ 66 lb.-ft.)</p> <p>Total Power Output: 441 kW (600 hp), 840 Nm (620 lb.-ft.)</p> <p>Driving Performance: 0-100 km/h: 3.9 s, v_{max}: 290 km/h</p>	058.300.590.009	<input type="checkbox"/> <input type="checkbox"/> <input type="checkbox"/> <input type="checkbox"/> <input type="checkbox"/> <input checked="" type="checkbox"/>
<p>TECHART Motorleistungssteigerung TA 058/T2 + 132 kW (+ 180 PS), + 170 Nm</p> <p>Gesamtleistung: 514 kW (700 PS), 920 Nm</p> <p>Fahrleistungen: 0-100 km/h: 3,9 s, v_{max}: 308 km/h</p>	<p>TECHART Engine Powerkit TA 058/T2 + 132 kW (+ 180 PS), + 170 Nm (+ 125 lb.-ft.)</p> <p>Total Power Output: 514 kW (700 hp), 920 Nm (679 lb.-ft.)</p> <p>Driving Performance: 0-100 km/h: 3.9 s, v_{max}: 308 km/h</p>	058.300.720.009	<input type="checkbox"/> <input type="checkbox"/> <input type="checkbox"/> <input type="checkbox"/> <input type="checkbox"/> <input checked="" type="checkbox"/>

¹ Nur für Cayenne Turbo.
¹ Only for Cayenne Turbo.

Cayenne
Cayenne Diesel / S Diesel
Cayenne S
Cayenne S E-Hybrid
Cayenne GTS
Cayenne Turbo / Turbo S





Motorleistung

Performance

Cayenne
 Cayenne Diesel / S Diesel
 Cayenne S
 Cayenne S E-Hybrid
 Cayenne GTS
 Cayenne Turbo / Turbo S

TECHART Abgasanlage »Sport«

TECHART Exhaust System »Sport«

058.310.891.009

TECHART Sport-Endrohre

in Kohlefaser matt mit Edelstahl-Innenrohr

TECHART Sport Tailpipes

matt carbon fiber with stainless steel inner pipe

058.310.948.009

in Kohlefaser hochglänzend mit Edelstahl-Innenrohr

glossy carbon fiber with stainless steel inner pipe

058.310.949.009

<input type="checkbox"/>	<input type="checkbox"/>	<input type="checkbox"/>	<input type="checkbox"/>	<input type="checkbox"/>
<input checked="" type="checkbox"/>	<input type="checkbox"/>	<input type="checkbox"/>	<input type="checkbox"/>	<input type="checkbox"/>
<input checked="" type="checkbox"/>	<input type="checkbox"/>	<input type="checkbox"/>	<input type="checkbox"/>	<input type="checkbox"/>

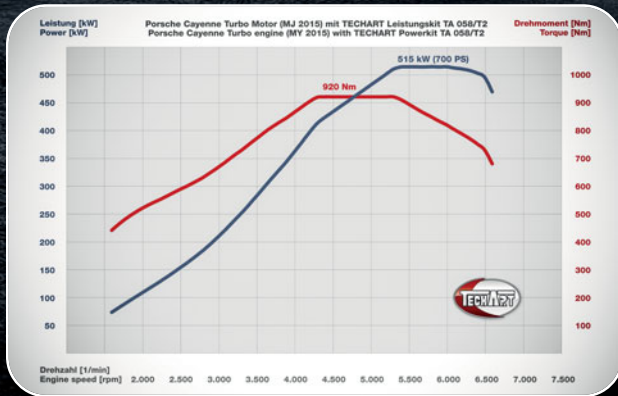

² Für Cayenne V6 nur in Verbindung mit Porsche Sportabgasanlage ab Werk, Code OP8.

² For Cayenne V6 only in conjunction with Porsche factory sports exhaust system, Code OP8.

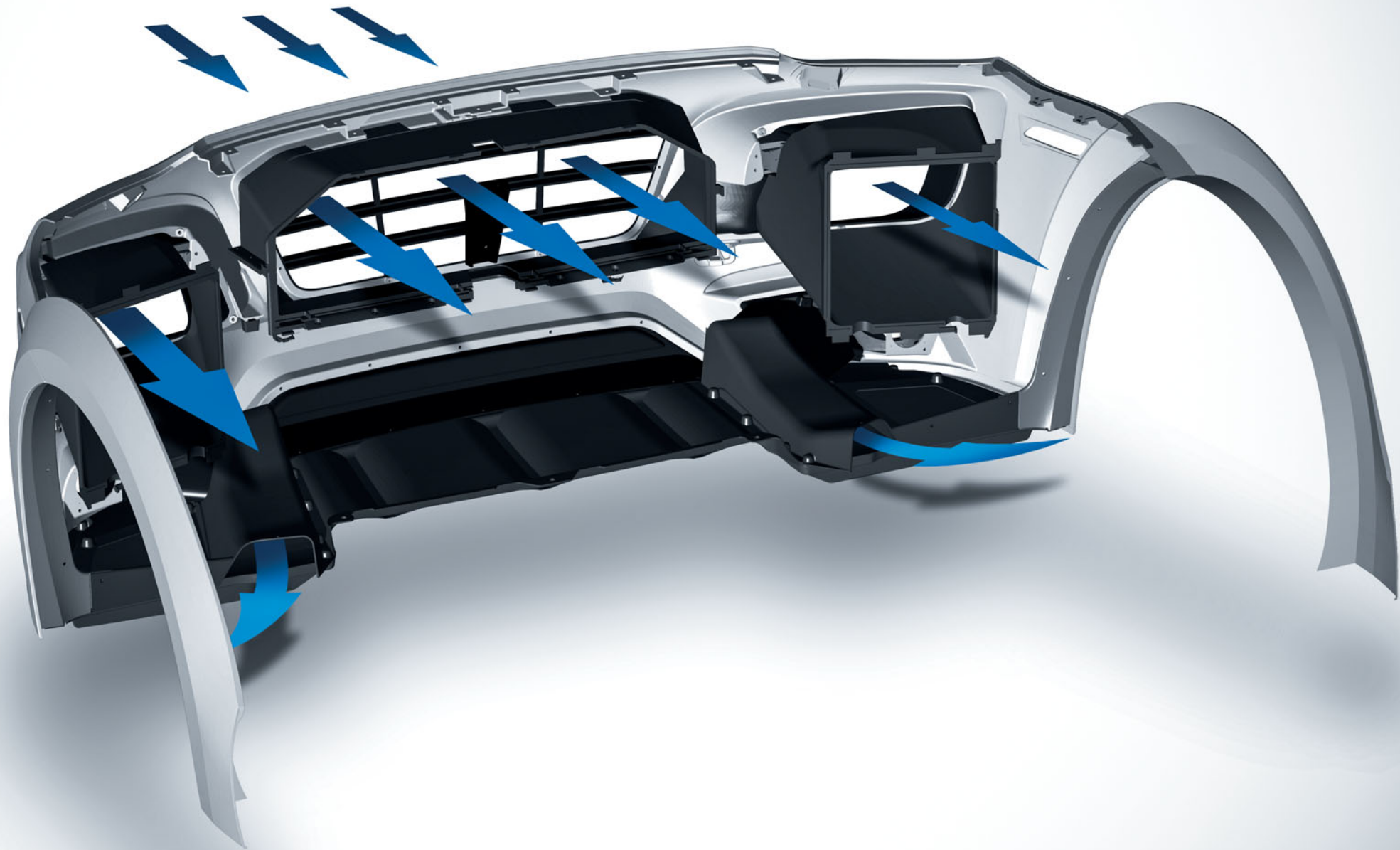



TURBO



Arbeitsnummer:
Laufende Nr.:
Herstellungsdatum:

TURBOLADER

058.300.650.301
Zyl. 5-8
000128

Fahrwerk

Chassis

TECHART Luftfederungsmodul »Sport«

Um 22 mm tiefergelegtes Fahrwerk im Normalniveau gegenüber der herkömmlichen Luftfederung ab Werk sowie tieferes Beladungsniveau als im Serienmodell. Inklusive TECHART Sonderfunktion automatische Parkabsenkung bei Verriegelung des Fahrzeugs.

TECHART Air Suspension Module »Sport«

Normal Level ride height is lowered by 22 mm compared to the standard air suspension. The Loading Level is lower compared to the series model. The system includes the exclusive TECHART feature Automatic Parking Level, which lowers the vehicle at front and rear when the car is locked.

058.200.285.009

Cayenne
Cayenne Diesel / S Diesel
Cayenne S
Cayenne S E-Hybrid
Cayenne GTS
Cayenne Turbo / Turbo S

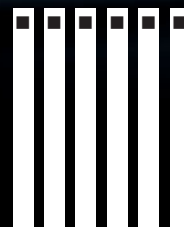

TECHART Formula



TECHART Formula III



TECHART Formula II



TECHART Formula IV

Räder

Wheels

Cayenne
Cayenne Diesel / S Diesel
Cayenne S
Cayenne S E-Hybrid
Cayenne GTS
Cayenne Turbo / Turbo S

<p>TECHART Formula Leichtmetallrad</p> <p>Fünf Speichen Rad. Besonders elegantes, klassisches Design, erhältlich in 20- bis 23-Zoll. Varianten: Shiny Silber, Schwarz hochglänzend oder Ausführung Individual.</p>	<p>TECHART Formula Wheel</p> <p>Five Spokes Wheel. A renowned and elegant design classic, available in 20- to 23-inch. Diversity: Shiny Silver, Gloss Black or Individual Color Match</p>	<p>[...].210.[...].[...]</p>	<p>█ █ █ █ █ █</p>
<p>TECHART Formula II Leichtmetallrad</p> <p>Fünf Speichen Rad in mehrteiliger Optik sowie mit austauschbarem Edelstahl-Anfahrschutz. Erhältlich in 22- und 23-Zoll. Varianten: Shiny Silber, Schwarz hochglänzend oder Ausführung Individual.</p>	<p>TECHART Formula II Wheel</p> <p>Five Spokes Wheel in multi-part look with exchangeable stainless steel wheel protection hump. Available in 22- and 23-inch. Diversity: Shiny Silver, Gloss Black or Individual Color Match.</p>	<p>[...].212.[...].[...]</p>	<p>█ █ █ █ █ █</p>
<p>TECHART Formula III Schmiederad</p> <p>Doppelspeichen Schmiederad mit besonders geringem Eigengewicht. Erhältlich in 21- und 22-Zoll. Varianten: Sterling Silber oder Ausführung Individual.</p>	<p>TECHART Formula III Forged Wheel</p> <p>Particularly low weight Twin Spokes Wheel. Available in 21- and 22-inch. Diversity: Sterling Silver or Individual Color Match.</p>	<p>055.215.[...].[...]</p>	<p>█ █ █ █ █ █</p>
<p>TECHART Formula IV Leichtmetallrad</p> <p>Doppelspeichen Rad mit besonders geringem Eigengewicht. Erhältlich in 22-Zoll. Varianten: Bicolor Grau/glanzgedreht, Bicolor Schwarz/glanzgedreht oder Ausführung Individual.</p>	<p>TECHART Formula IV Wheel</p> <p>Particularly low weight Twin Spokes Wheel. Available in 22-inch. Diversity: in Bi-Color Grey/Gloss Turned, Bi-Color Black/Gloss Turned or Individual Color Match.</p>	<p>058.214.105.[...]</p>	<p>█ █ █ █ █ █</p>





Interieur

Interior

TECHART 3-Speichen Sportlenkrad

Ergonomisch geformt, Bezug in Individualfarbe aus Leder mit handgefertigter Ziernaht. Passend für Serien-Airbageinheit

TECHART 3-spokes sport steering wheel

Ergonomic shape, made of fine leather in custom color with hand sewed stitching. Fits the series airbag unit

B95.430.376.CCC

TECHART Exklusiv Lederausstattung

Manufaktur-Interieur in TECHART Design mit Einzelsitzanlage und Mittelkonsole im Fond. Sitze mit Soft-Comfort Polsterung, im Fond mit Komfort-Kissen in Leder.

TECHART Exclusive Leather Interior

Handcrafted TECHART Design Interior with rear single seats unit and rear center console. All seats feature a Soft-Comfort upholstery, rear seats include two cozy leather pillows.

058.407.060.000

Lederausstattungsumfang: Armaturenbrett Ober- und Unterteile, Kombiinstrument, Mittelkonsoleneinheit, Airbag, Türverkleidungen, Türgriffe, Zierblenden, Armlehnen, Sitze inkl. Verblendungen, A-/B-/C-/D-Säulenverkleidungen, Dachhimmel (Alcantara), Sonnenblenden, Gepäckraum, Heckklappenverkleidungen, Gepäckraumabdeckung, Fußraum in Leder-/Teppichkombination, Fußmatten mit Softpolsterung und Ledereinfassung, Gepäckraummatte mit Ledereinfassung.

Leather Interior: upper and lower dashbord unit, instrument cluster, center console unit, Airbag, door panels, door handles, trim panels, armrests, seats including trims and panels, interior A-/B-/C- and D-pillar covering, roof liner (Alcantara), sun visors, luggage compartment, rear hatch covering luggage compartment cover, flooring in leather-/carpet combination, floor mats with comfort upholstery and leather edging, luggage compartment mat with leather edging.

Cayenne

Cayenne Diesel / S Diesel

Cayenne S

Cayenne S E-Hybrid

Cayenne GTS

Cayenne Turbo / Turbo S

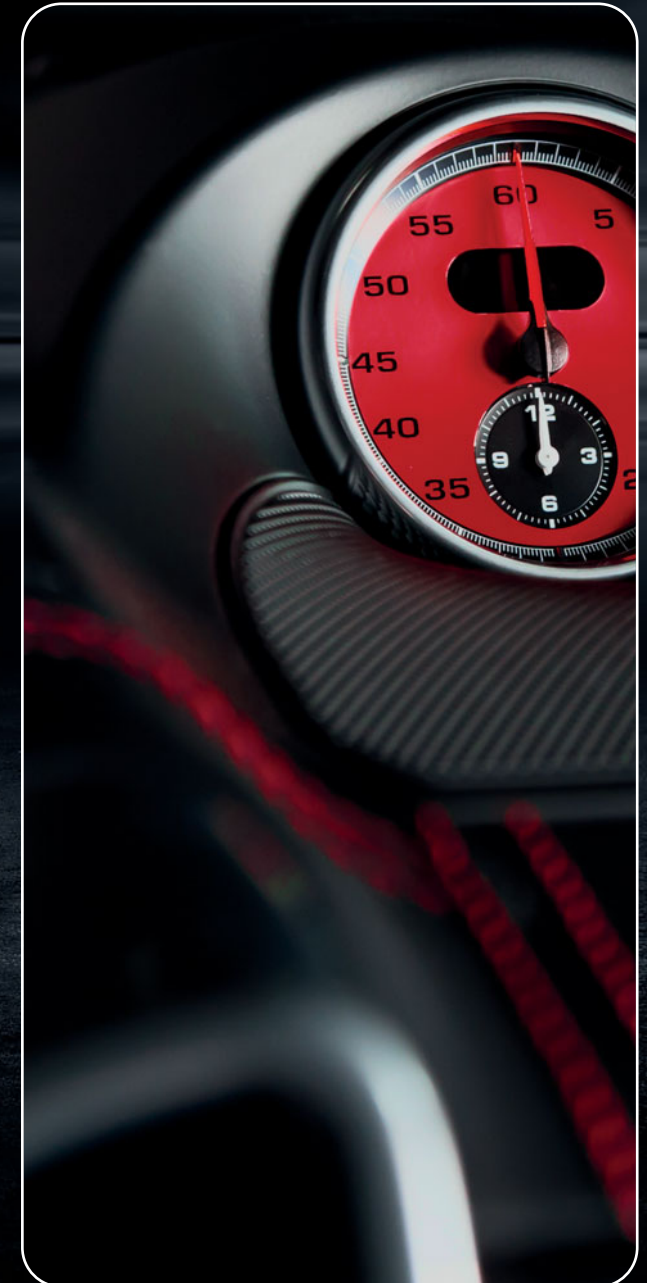
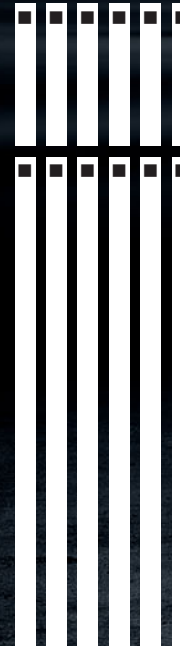







MAGNUM

295/30 ZR

Continental



TECHART Automobil design GmbH
Röntgenstraße 47, 71229 Leonberg, Germany

Tel. +49 (0)7152 9339-0, Fax +49 (0)7152 9339-33, E-Mail info@techart.de, <http://www.techart.de>
Errors and omissions excepted. Subject to change without notice.

058.991.119.003, 11/2015

Copyright by TECHART Automobil design GmbH