

WIDS-515A-H61

15" IP65 Heavy Industrial Panel PC with Wi-Fi

WIDS-517A-H61

17" IP65 Heavy Industrial Panel PC with Wi-Fi



Features

- Intel® H61 Express Chipset with 2nd/3rd Generation Intel® Core™, Pentium® and Celeron® processor
- Built-in mini PCIe 802.11b/g/n wireless module for panel mount installation
- High brightness TFT-LCD panel with LED backlight
- Multiple storage options: 2.5" SATA HDD, CF slot, and mSATA
- Dual Ethernet provides continuous network service and allows sharing among different workgroups in two different subnets
- Optional PCI / PCIe by 1 expansion slot
- Optional Slim type CD-ROM drive bay
- IP 65 compliant front panel
- IEI One Key Recovery solution allows you to create rapid OS backup and recovery (Over 4GB storage capacity)



Specifications

Model		WIDS-515A	WIDS-517A	
Display	LCD Size	15"	17"	
	Max Resolution	1024(W) x 768(H)	1280(W) x 1024(H)	
	Brightness (cd/m ²)	400	350	
	Contrast Ratio	700:1	800:1	
	LCD Color	16.2M	16.7M	
	Pixel Pitch (mm)	0.297 x 0.297	0.264 x 0.264	
	Viewing Angle (V-H)	140°/160°	170°/160°	
	Backlight MTBF (hrs)	50,000	50,000	
Motherboard	SBC Model	POS-H61	POS-H61	
	CPU	2nd/3rd Generation Intel® Core™ i7/ i5/ i3, Pentium® and Celeron® processor	2nd/3rd Generation Intel® Core™ i7/ i5/ i3, Pentium® and Celeron® processor	
	Chipset	Intel® H61	Intel® H61	
	RAM	Support 2 x 204-pin DDR3 SO-DIMM slot (max. 16G)	Support 2 x 204-pin DDR3 SO-DIMM slot (max. 16G)	
I/O Ports and Switches		4 x RS232 COM Port 1 x RS-232/422/485 Port 2 x RJ-45 for LAN Port 2 x SFP Fiber LAN 4 x USB 2.0 & 2 x USB3.0 on rear 2 x USB 2.0 on front 1 x VGA Port 1 x Audio (Line-out, MIC-in) 1 x Power Switch 1 x AT / ATX Switch 1 x PCI/ PCIe expansion slot	4 x RS232 COM Port 1 x RS-232/422/485 Port 2 x RJ-45 for LAN Port 2 x SFP Fiber LAN 4 x USB 2.0 & 2 x USB3.0 on rear 2 x USB 2.0 on front 1 x VGA Port 1 x Audio (Line-out, MIC-in) 1 x Power Switch 1 x AT / ATX Switch 1 x PCI/ PCIe expansion slot	
	Driver Bay	HDD Driver Bay: 1 x 2.5" SATA HDD bay with anti-shook SSD: CF Type II, mSATA (optional) CD-ROM Driver Bay: Slim Type CD-ROM Bay	HDD Driver Bay: 1 x 2.5" SATA HDD bay with anti-shook SSD: CF Type II, mSATA (optional) CD-ROM Driver Bay: Slim Type CD-ROM Bay	
	Wireless	IEEE 802.11b/g/n 2T2R mode WLAN via internal PCIe Mini card interface	IEEE 802.11b/g/n 2T2R mode WLAN via internal PCIe Mini card interface	
	Extension Slot	Either 1 x PCI slot or 1 x PCIe slot 1 x PCIe mini card	Either 1 x PCI slot or 1 x PCIe slot 1 x PCIe mini card	
	Physical	Construction Front Panel	Aluminum	Aluminum
		Construction Chassis	Heavy-duty Steel	Heavy-duty Steel
		Mounting Front Panel Color	Panel, Wall, Rack, Stand and Arm VESA 100mm x 100mm Silver (Pantone 8001C)	Panel, Wall, Rack, Stand and Arm VESA 100mm x 100mm Silver (Pantone 8001C)
		Dimension (WxHxD) (mm)	410 x 329 x 123	452 x 376 x 123
		Net Gross Weight	7 Kg / 11 Kg	8 Kg / 12 Kg
		Operation Temperature (°C) (Ambient with air flow)	-20°C ~ 60°C	-20°C ~ 60°C
Environment				
Storage Temperature (°C)		-30°C ~ 70°C	-30°C ~ 70°C	
Humidity		10% to 95% (non-condensing)		
Vibration		5~17Hz, 0.1" double amplitude displacement 17~640Hz, 1.5G acceleration peak to peak	5~17Hz, 0.1" double amplitude displacement 17~640Hz, 1.5G acceleration peak to peak	
Shoock	10G acceleration part to part (11ms)			
Touch Screen	Resistive Type 5-Wire with RS-232 interface			
Power Supply	ATX AC-Input	AC Input ATX power supply - P/N: 63000-ACEA622A166-RS - 220W power supply - Input: 90VAC~264VAC, 50/60Hz - Output(max.): 3.3V@14A, 5V@16A, 12V@10A, -12V@0.8A	AC Input ATX power supply - P/N: 63000-ACEA622A166-RS - 220W power supply - Input: 90VAC~264VAC, 50/60Hz - Output(max.): 3.3V@14A, 5V@16A, 12V@10A, -12V@0.8A	
	DC Input	DC Input ATX power supply - P/N: ACE-4520C-RS - 200W power supply - Input: 24 VDC(18~36 VDC) - Output(max.): 3.3V@12A, 5V@12A, 12V@15.4A, -12V@0.5A	DC Input ATX power supply - P/N: ACE-4520C-RS - 200W power supply - Input: 24 VDC(18~36 VDC) - Output(max.): 3.3V@12A, 5V@12A, 12V@15.4A, -12V@0.5A	

Fully Integrated I/O

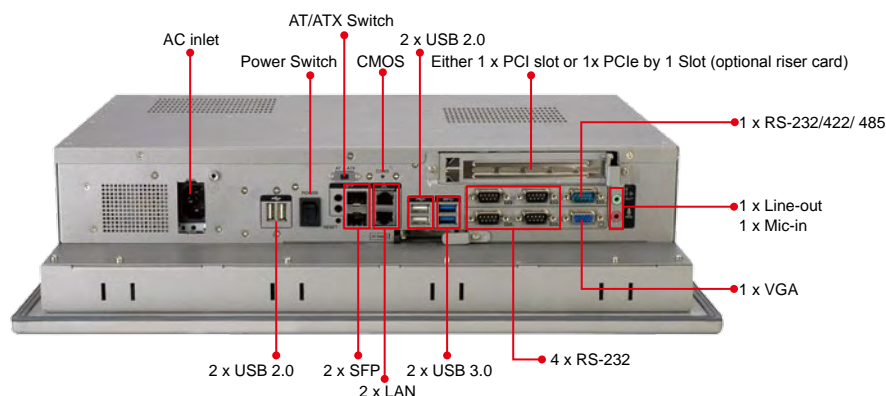

Ordering Information

Part No.	Description
15"	WIDS-515A-H61-P/R-R10 15" 400 cd/m2 XGA Panel PC with POS-H61, Pentium Dual Core G6xxT (Above 2.2GHz), TDP 35W, 2GB DDR3 RAM*2, 802.11 b/g/n wireless module, Silver color, PSU ACE-A622A, touch screen, RoHS
	WIDS-515AD-H61-P/R-R10 15" 400 cd/m2 XGA Panel PC with POS-H61, Pentium Dual Core G6xxT (Above 2.2GHz), TDP 35W, 2GB DDR3 RAM*2, 802.11 b/g/n wireless module, Silver color, PSU ACE-4520C, touch screen, RoHS
	WIDS-515A-H61-i3/R-R10 15" 400 cd/m2 XGA Panel PC with POS-H61, Core i3 Dual Core 2xxxT CPU (Above 2.5GHz), TDP 35W, 2GB DDR3 RAM*2, 802.11 b/g/n wireless module, Silver color, PSU ACE-A622A, touch screen, RoHS
	WIDS-515AD-H61-i3/R-R10 15" 400 cd/m2 XGA Panel PC with POS-H61, Core i3 Dual Core 2xxxT CPU (Above 2.5GHz), TDP 35W, 2GB DDR3 RAM*2, 802.11 b/g/n wireless module, Silver color, PSU ACE-4520C, touch screen, RoHS
	WIDS-515A-H61-i5/R-R10 15" 400 cd/m2 XGA Panel PC with POS-H61, Core i5 Dual Core 2xxxTCPU (Above 2.7GHz), TDP 35W, 2GB DDR3 RAM*2, 802.11 b/g/n wireless module, Silver color, PSU ACE-A622A, touch screen, RoHS
	WIDS-515AD-H61-i5/R-R10 15" 400 cd/m2 XGA Panel PC with POS-H61, Core i5 Dual Core 2xxxTCPU (Above 2.7GHz), TDP 35W, 2GB DDR3 RAM*2, 802.11 b/g/n wireless module, Silver color, PSU ACE-4520C, touch screen, RoHS
17"	WIDS-517A-H61-P/R-R10 17" 350 cd/m2 SXGA Panel PC with POS-H61, Pentium Dual Core G6xxT (Above 2.2GHz), TDP 35W, 2GB DDR3 RAM*2, 802.11 b/g/n wireless module, Silver color, PSU ACE-A622A, touch screen, RoHS
	WIDS-517AD-H61-P/R-R10 17" 350 cd/m2 SXGA Panel PC with POS-H61, Pentium Dual Core G6xxT (Above 2.2GHz), TDP 35W, 2GB DDR3 RAM*2, 802.11 b/g/n wireless module, Silver color, PSU ACE-4520C, touch screen, RoHS
	WIDS-517A-H61-i3/R-R10 17" 350 cd/m2 SXGA Panel PC with POS-H61, Core i3 Dual Core 2xxxT CPU (Above 2.5GHz), TDP 35W, 2GB DDR3 RAM*2, 802.11 b/g/n wireless module, Silver color, PSU ACE-A622A, touch screen, RoHS
	WIDS-517AD-H61-i3/R-R10 17" 350 cd/m2 SXGA Panel PC with POS-H61, Core i3 Dual Core 2xxxT CPU (Above 2.5GHz), TDP 35W, 2GB DDR3 RAM*2, 802.11 b/g/n wireless module, Silver color, PSU ACE-4520C, touch screen, RoHS
	WIDS-517A-H61-i5/R-R10 17" 350 cd/m2 SXGA Panel PC with POS-H61, Core i5 Dual Core 2xxxTCPU (Above 2.7GHz), TDP 35W, 2GB DDR3 RAM*2, 802.11 b/g/n wireless module, Silver color, PSU ACE-A622A, touch screen, RoHS
	WIDS-517AD-H61-i5/R-R10 17" 350 cd/m2 SXGA Panel PC with POS-H61, Core i5 Dual Core 2xxxTCPU (Above 2.7GHz), TDP 35W, 2GB DDR3 RAM*2, 802.11 b/g/n wireless module, Silver color, PSU ACE-4520C, touch screen, RoHS
Riser Card	PCIR-01H-R10 1-Slot PCI riser card
	PCIER-101H-R10 1-Slot PCIe x1 riser card

Packing List

Item	Part No.	Description
Power Cord	32000-000002-RS	EUROPEAN Standard ,1830MM, PLUG(16A 250V), CONNECTOR (16A 250V)
Panel Mount Kit	19Z00-000024-RS	
Wall Mount Kit	41020-016102-00-RS	
IEI One Key Recovery CD	IEI-7B000-000478-RS	
Touch Pen		
User's Manual CD-ROM		

IQ Mounting Options

Item	P/N
Rack Mount Kit	WIDSRK-150MS-R10 (for WIDS-515A series) WIDSRK-170MS-R10 (for WIDS-517A series)
ARM	ARM-31-RS
STAND	STAND-210-R11

Options

Part Number	Description
73400-AD7760H01-RS	Slim type SATA DVD-ROM

WIDS-515A-H61

Dimensions

(Unit: mm)

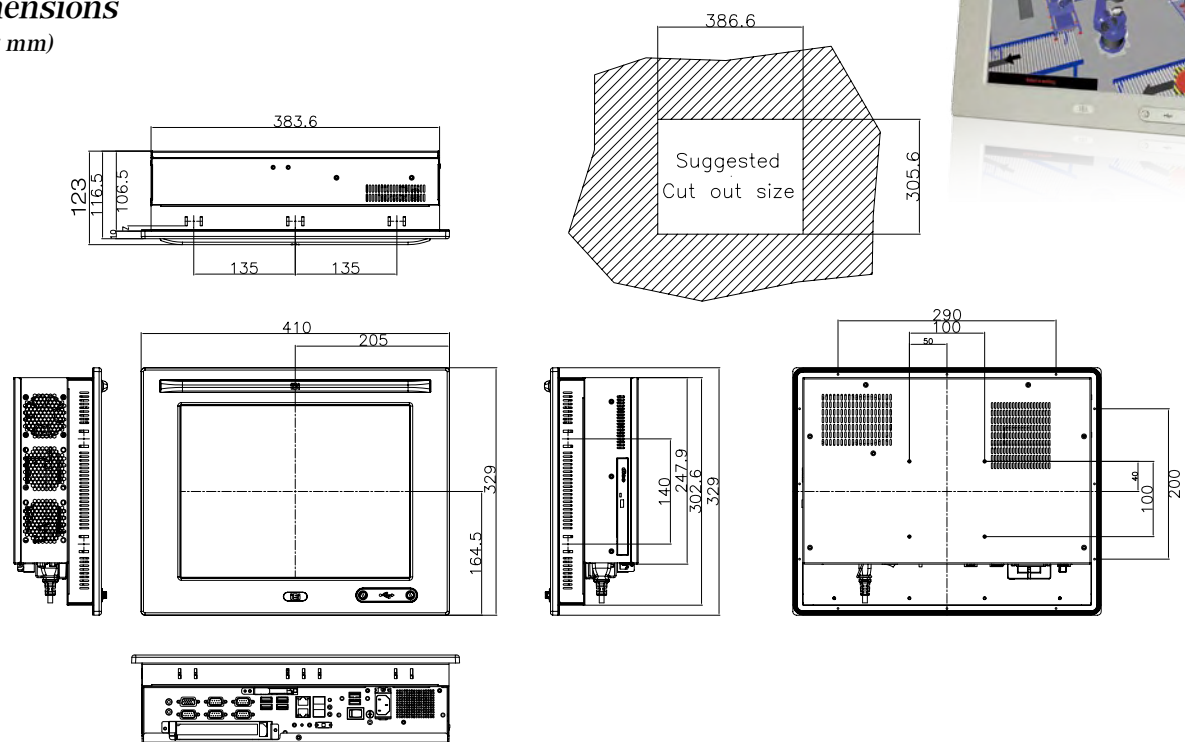

WIDS-517A-H61

Dimensions

(Unit: mm)

