

## Press Release

### Jetter at the FachPack 2016

Jetter AG  
Gräterstraße 2  
71642 Ludwigsburg

Phone +49 (0) 7141 2550-0  
Fax +49 (0) 7141 2550-425  
info@jetter.de  
www.jetter.de

<b>Contact</b> Jochen Weyershäuser	<b>Direct access</b> Tel. 462   Fax 484	<b>email</b> pr@jetter.de	<b>Date</b> 07.09.16
---------------------------------------	--	------------------------------	-------------------------

#### **Motion Control platforms for packaging machines. Jetter AG will present integrated automation concepts at the FachPack 2016**

The amount of motion systems applied in modern machine building industry increases continually. Besides uncomplicated positioning tasks, complex motion sequences have to be implemented more and more often. That's where the classical PLC system reaches its limits. Especially in packaging machine building industry, Motion Control systems can demonstrate their strengths.

The following packaging applications benefit partially or as a whole from the Motion Control systems by Jetter AG: Horizontal form-fill-seal (HFFS) machines, vertical form-fill-seal (VFFS) machines, thermoform fill and seal (TFFS) machines, horizontal folding-box cartoning machines and labeling machines. At the FachPack 2016, Jetter AG presents a scalable automation concept applied to a horizontal form-fill-seal machine.

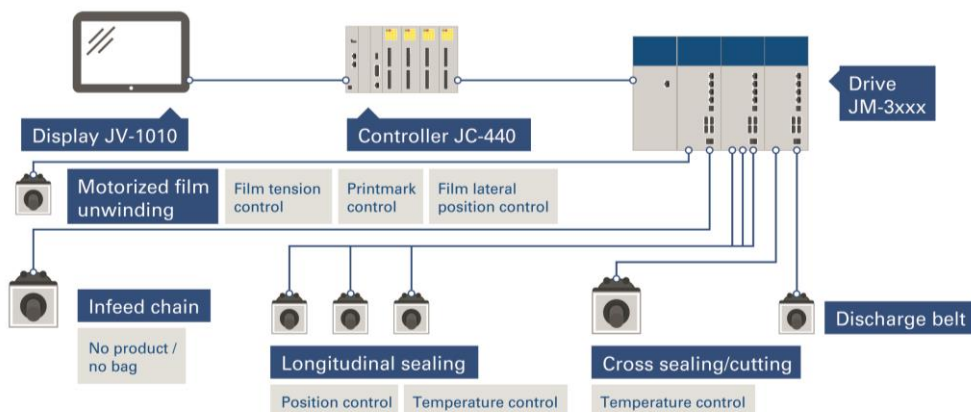

**Image: automation solution of a horizontal form-fill-seal machine**

A core aspect of horizontal form-fill-seal packaging is film tension. This is why electronic tension control is often combined with torque-monitored film handling. The No-product-no-bag feature which is essential for horizontal form-fill-seal machines is supported by coupling and decoupling of axes or axis groups. Film tension remains unchanged, while there is no waste of material.

Print-mark control ensures the printed pattern on the film to be synchronized with the position of the product. Cross-sealing, as well as cross-cutting are rotatory or in concurrent mode (Box Motion) controlled by electronic cam discs and drives. The temperature of the sealing units is controlled depending on the film velocity.

To increase flexibility of the plants, parameters can be changed during operation.

There are also various requirements posed by filling machines. The sheer variety of applications sets the bar high with regard to automation solutions. In addition to ensuring the automated processes, the high cycling rate of the machines is the primary focus. At the FachPack 2016, Jetter AG presents an integrated automation concept applied to a filling plant to demonstrate servo filling and torque-controlled capping supported by look-ahead limit stop detection.

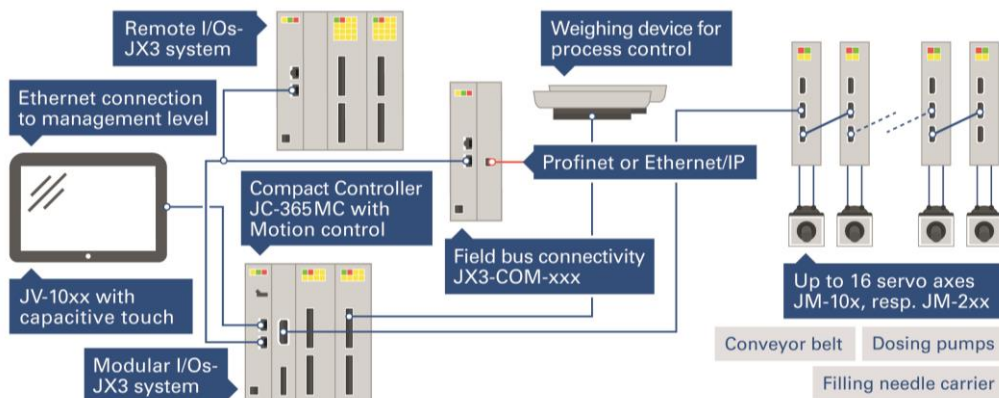

**Image: automation solution servo filling**

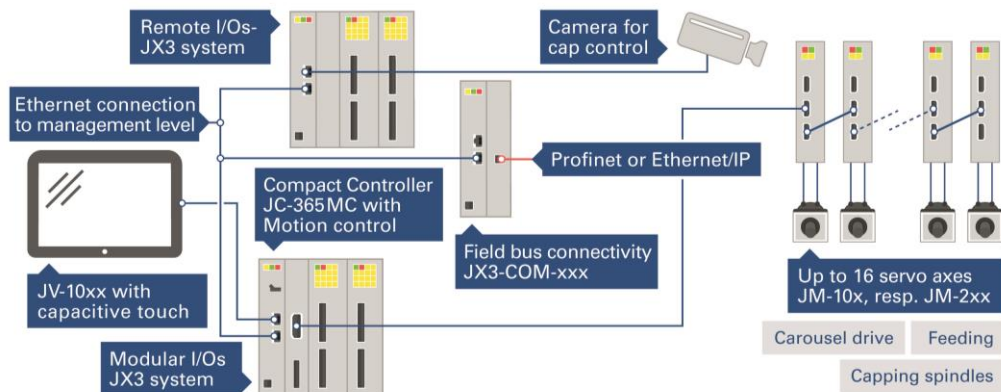

Image: automation solution torque-controlled capping

### The new control system JetControl 440MC

At the core of the automation concept is the new Motion Control system JetControl 440MC, which will be presented to the public for the first time at the FachPack 2016. The JetControl 440MC lets you control and monitor the complete process chain whether of individual packaging machines or of entire packaging lines. Further, the JetControl 440MC distinguishes itself by high performance, yet compact design. It is the optimum solution for CPU-demanding and large applications. This way, it lets you enter into Motion Control functionality in connection with servo amplifiers of the JetMove 1000/3000 series, which will also be presented as part of our automation concept at our trade fair stand. It allows for easy programming of axis groups and complex path control applications.



Image: JetControl 440MC

Integrated automation concepts by Jetter AG comprising Motion Control systems allow for packaging machines to be equipped with perfectly synchronized automation components. The integrated Motion Control systems of the Ludwigsburg based specialist for automation solutions comprise PLC, technological drive functions and path control. Machine sequences can easily be mapped to controller programs as sequentially processed tasks. The programming language STX based on IEC 61131-3 lets you easily implement any automation feature whatsoever. Transparent access to all system elements and programming continuity significantly reduce programming and commissioning times.

**Jetter AG, Hall 3, Stand 634**

---

### **About Jetter**

For over 35 years, Jetter AG has been developing, producing, and engineering both integrated and open automation solutions for various lines of business. These solutions comprise perfectly coordinated software and hardware components, which, whether being part of a system or cooperating with other components, contribute to a remarkable increase of efficiency. By consistently supporting both open and established standards, products by Jetter AG guarantee maximum flexibility at any time. Jetter AG was the first company in the world to focus on consistent and universal networking with Ethernet-TCP/IP and the use of web technologies. The Mobile Automation division has been developing and manufacturing HMIs and control systems for mobile applications such as agricultural machinery, municipal vehicles, railway vehicles and fire engines for many years.